



The Science of Coal Dust Suppression

White Paper



ENGINEERING **YOUR** SUCCESS.

Coal mining presents a number of specific hazards, ranging from collapse and flooding to dangerous explosions. Dust created by mining activities presents a hazard because its pervasive nature creates a number of breathing-related issues for people, as well as maintenance issues for machinery. Dust also creates a potentially explosive environment.

Every year, an unacceptable number of people are injured or killed in underground coal mining accidents or suffer long-term health issues as a consequence of exposure to coal dust.

However, many countries have demonstrated that, by applying rigorous safety standards, it is possible to dramatically reduce the risks associated with working in an underground mine. Parker Conflow plays a significant part in this, by providing a product range specifically developed in conjunction with coal mining engineers to use water to address

the major underground health and safety issues, such as frictional ignition, dust suppression and fire control.

Coal dust is a proven carcinogen and also causes pneumoconiosis (more commonly known as miners' lung disease) so suppression of coal dust in an underground mine is critical. High levels of dust in the atmosphere when mixed with gas can also create an ignition hazard, in addition to being a source of premature wear and breakdowns on various pieces of mining equipment. There are many different types of dust suppression. A bag filter system will use fans to extract air from an area and leave dust in a bag. When the bag is full, it must be changed or emptied, so is therefore not a practical proposition underground. A dry fog system can be used in certain applications, but as this is electrically activated/power, it is also not practical underground. An ideal solution is one that can make use of a mine's existing water



Gary Wain, Product Manager
Parker Conflow

supply in the form of a spray to suppress the dust, ideally as soon as the dust is generated at the coal extraction point, as well as at all other subsequent points where dust can be generated – crushers, belt transfer points, etc. Another requirement in many parts of the world is that the system has to be mechanical – ideally activated by a combination of water pressure, belt movement and the presence of coal on the belt itself.

Preventative vs corrective dust suppression

As with any problem, if it can be prevented from occurring in the first instance then the effort (and cost) spent in corrective actions is minimised. Preventing dust from becoming airborne in the first place is therefore of vital importance in dust suppression. There are typically three elements to this: control, filter and spray.

- **Control:** this relates to how the water to the system is controlled. For example, it may be controlled

by the presence of coal on the conveyor or by the motion of the belt, so that water can be isolated before entering the system.

- **Filter:** this ensures the water is sufficiently clean or free of contaminants, so that the system operates correctly.
- **Spray:** this relates to the need to control the amount and pattern of

water that is delivered to the coal. A measured amount of water is sprayed onto the surface of the coal immediately before dust is likely to be generated i.e. before and as the coal is cut, before the coal is crushed and immediately before conveyor transfer points, etc. Figure 1 shows how this can be achieved.

Figure 1. A typical belt conveyor transfer point dust suppression system has two options: paddle valve (A) or belt driven valve (B). Both are designed to operate only when there is coal on the conveyor.

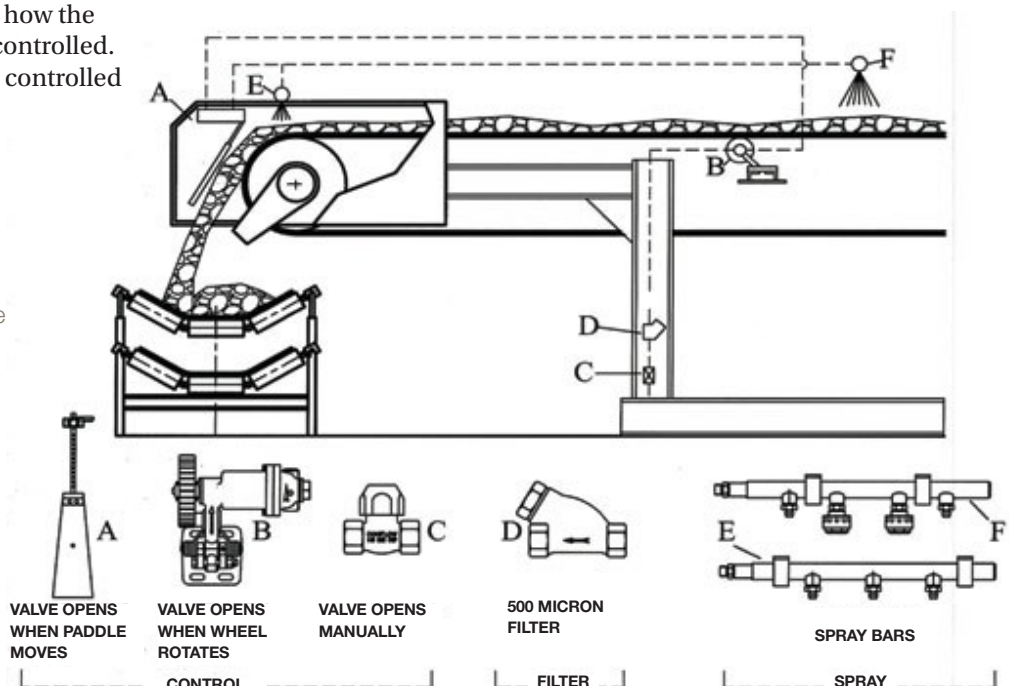

Corrective dust control – sometimes called symptomatic dust control – is generally a tougher proposition. Dust particle size is measured in microns and is typically of a size between 50 – 70 μm . There are, of course, dust particles larger than this (which tend to settle in the immediate vicinity of whatever is generating the dust) and dust particles smaller than this. It has been shown that dust particles of 20 μm or less can remain airborne for a very long time and can find their way onto and into machinery, into lungs and also into areas outside of the mine itself. Dust particles

less than 10 μm in size are invisible to the naked eye and can remain suspended in the air indefinitely. Generally, the smaller the particle size, the more hazardous it is to human health and mining equipment. Furthermore, the smaller the particle size, the harder it is to remove from the atmosphere. Airborne coal dust underground, if not dealt with preventatively, can be dealt with correctively once again using sprays. The principle here is that the dust agglomerates with the water, causing it to fall under gravity. However, it is not just a question of providing a water

spray. If the water droplets are too large in size, then the airborne dust particles are just moved around in the resulting air currents and very little dust is removed from the air. Too much water also means a very soggy working environment and can lead to belt slip. For the coal dust to be removed from the air, the water particles need to be of a similar size. This in turn means a collision between dust particle and water droplet is more likely (Figure 2).

Figure 2. The effect of water droplet size on dust suppression.

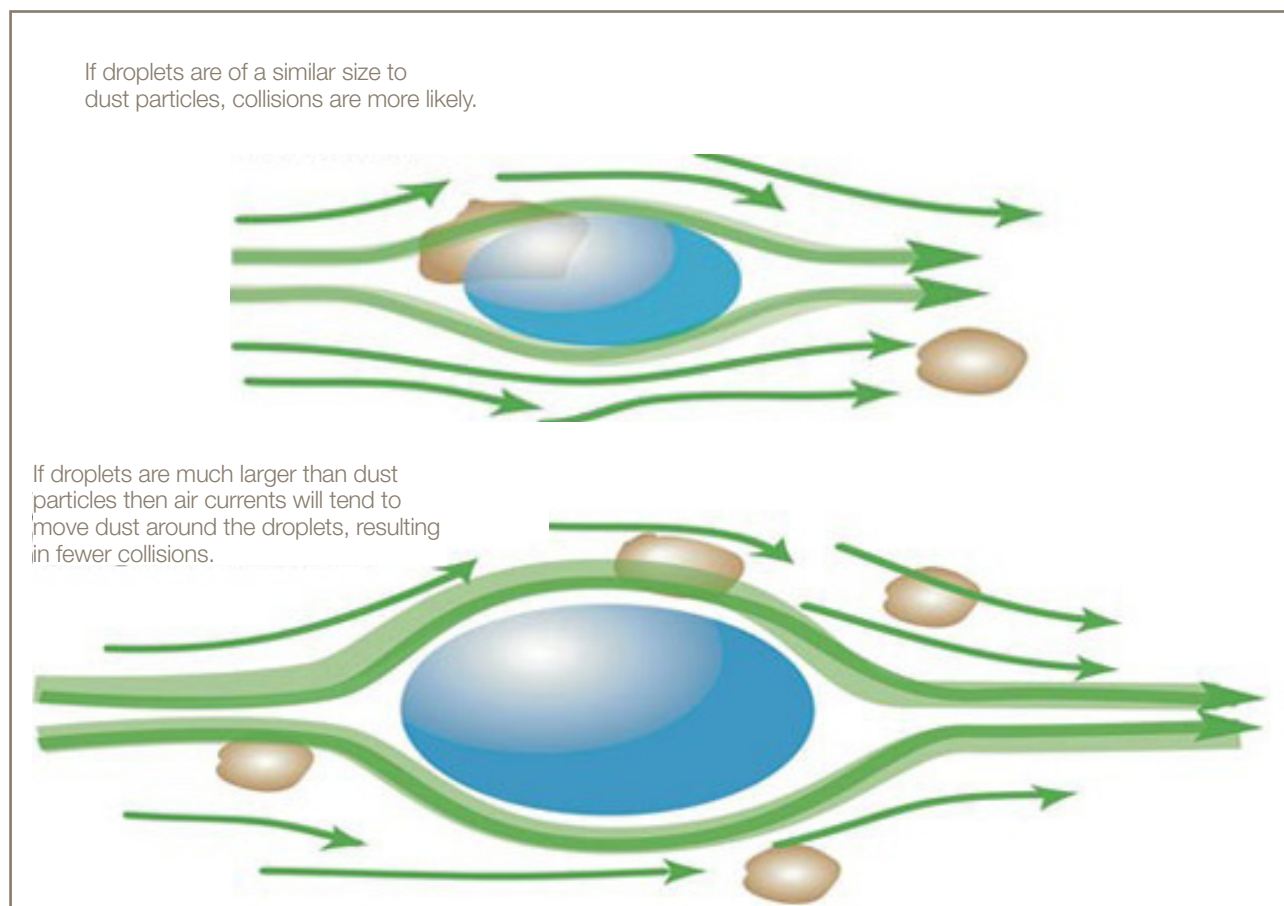

The design of spray head is therefore of paramount importance in ensuring the right volume and size of water droplets is delivered. With preventative dust suppression, droplet size is less important. Parker Conflow is continuously working with mines and mining equipment manufacturers to improve and develop new products to protect equipment

and personnel from the harmful effects of waterborne and airborne dust. Environmental and health and safety legislation differs from country to country, but everywhere it is becoming tighter and tighter. Not only does it make sense from the point of employee health, but it also makes sense commercially: less equipment downtime, lower employee healthcare costs and

fewer mining disasters. Preventative dust suppression systems can be retrofitted to any existing installation and, assuming there is an adequate supply of water, the system can be operational in a matter of a couple of hours.

Case study: Dust suppression in Colombia

Two years ago, Parker Conflow secured a major new contract with Colombian producer of metallurgical coal, CI Milpa. This was the first contract that Parker Conflow had secured in the South American country, following brokering a relationship with CI Milpa through another Parker product brand, Bretby Gammatech. A team from Parker Conflow visited the CI Milpa mine in Bogota and fitted two dust suppression systems. Parker Conflow's engineers also fitted a fire suppression system on a roadway for Milpa in another

location in Bogata.

David Fernando Jaimes Mojica from CI Milpa said:

"We are focused on continually improving the efficiency and safety of our production sites and the Parker Conflow systems are an important part of this. We chose to work with Parker Conflow, because of the company's expertise in the manufacture and installation of dust and fire suppression systems and are very pleased with the result."

Gary Wain, product manager for

Parker Conflow, said:

"This is the start of a very positive relationship with CI Milpa and we are looking forward to further developing our business in Colombia. Because of the large amount of mining here, we see it as a major growth area for our business."

CI Milpa has been a customer of Parker Bretby Gammatech for several years, as the company has supplied a number of its Ash Probes to enable it to monitor the ash content of coal using natural gamma radiation.

Conclusion

In summary, prevention is better than cure. Parker Conflow systems are used worldwide. It is vital that companies continue to pioneer dust suppression, fire suppression and water control in mines and thereby make working in mines a considerably less risky proposition. Unfortunately, sometimes it takes a disaster before the importance of dust suppression is understood.

